

# MonAlit

DIAMOND TOOLS





## MonAlit 真空扩散钎焊技术

我们的金刚石和氮化硼磨具是采用最新的真空扩散钎焊磨具技术制造。金刚石颗粒相互强烈焊接。金刚石颗粒的浓度值高达70%，远远高于烧结或电偶技术的晶粒浓度。我们的技术可以产生一个直径70mm金刚石工具。金刚石砂轮可到尺寸为80mm



## MonAlit VDW-Technology

Our diamond and boron nitride tools are manufactured using the new VDW-Technology. Diamond grains are strongly welded with each other. The diamond grain concentration is much higher than the concentration in sintering techniques or galvanic bonds and reaches values up to 70%. With our technology we can produce diamond tools with a diameter of 70mm. Diamond wheels are available up to a size of 80mm.

### 使用真空扩散钎焊磨具的优势

- 较高的耐磨力
- 最高尺寸稳定性
- 光滑磨削表面图案
- 优良的热传导
- 最佳超声特性

### Advantages using VDW Tools

- Significant higher endurance
- Highest dimensional stability
- Smooth grinding surface pattern
- Excellent heat conduction
- Best ultrasonic characteristics

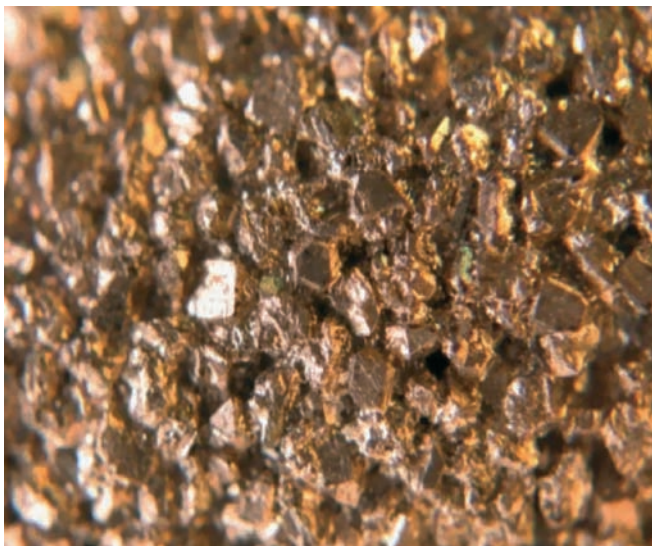

由于其较高的金刚石浓度MonAlit 真空扩散钎焊磨具有一个平滑的磨削表面的图案。  
请注意：要获得相同的粗糙度比传统的工具，使用双晶粒尺寸。

Because of its higher diamond grain concentration MonAlit VDW-Tools have a smoother grinding surface pattern. Please note: To get the same depth of roughness than with conventional tools, use the double grain size.



# 代码表

## Table of item codes

	特性 Characteristics	代码 Code	用途 Designation
第一部 Part 1	技术 Technology	M	MonAliT 真空扩散钎焊技术 / MonAliT VDW-Technology
	材料 Material	B	CBN / Boron Nitride
		D	金刚石 / Diamond
第二部 Part 2	产品应用 Product application	B	钻头 / Drilling Bit
		GP	扩孔钻头 / Countersink Drilling Bit
		MC	铣刀 / Milling Cutter
		GP	磨销 / Grinding Pin
		PB	断面研磨头 / Profile Bit
		W	轮型头 / Wheel
		C	扩孔磨头 / Countersink
		P	销 / Pin
第三部 Part 3	形状 Shape of the tool	C2	取芯 / Core
		F	火焰形 / Flame
		S3	直形 / Straight
		C1	锥形 / Cone
		C1T	截锥体 / Truncated Cone
		C1R	圆端锥形 / Rounded End Cone
		C1I	倒锥形 / Inversed Cone
		L	镜头形 / Lens
		S1	球形 / Sphere
		D	盘形 / Disc
		T	梯形形 / Trapezoidal
		C3	圆柱 / Cylinder
		C3R	圆端缸形 / Rounded End Cylinder
		H	马蹄形 / Horseshoe
		S2	螺旋形 / Spiral
		A1C2	可调 / Adjustable
		MC2	整体取芯 / Monoblock Core
		RE	外圆 / External Rounded
		RI	内圆 / Internal Rounded
		A2E	外部的角 / External Angular
第四部 Part 4	柄形状 Type of shank	T	1/2" 颈柄 / Shank with a thread of 1/2"
		T*	1/4" 颈柄 / Shank with a thread of 1/4"
		C	圆柱体柄 / Cylindrical shank
		U	CNC-头柄 / Shank for "CNC" Units



## 代码 Item Code

每个工具的代码由4部分组成。每个部分包含有关工具的特性的信息。

The code of each instrument consists of 4 parts. Each part contains information regarding the characteristics of the instrument.



**MD**

第一部  
Part 1

-

**DB**

第二部  
Part 2

-

**C2**

第三部  
Part 3

-

**C**

第四部  
Part 4

## 应用领域 Application Fields

应用领域 Application fields	材料 Materials
施工 Construction	混凝土、合成材料、砖 Concrete, synthetic materials, brick
玻璃工业 Glass industry	石英, 玻璃, 瓷器 Glass, quartz, porcelain
珠宝工业 Jewelry	宝石, 半宝石(雕刻), 金属 Gems, semi-precious stones (engraving), metals
加工工业** Processing industry**	陶瓷, 工业陶瓷, 硬质合金, 硬质合金, 复合材料, 复合材料, 超声波加工, 跳汰机 Ceramics, technical ceramics, hard metals, hard alloys, composites, compound, ultrasonic machining, jig grinding
石材行业 Stone industry	天然石材, 花岗岩, 陶瓷花岗岩, 大理石 Natural stone, granite, Ceram granite, marble

\*\* 包括航空, 汽车和工程工业,

\*\* including aviation, automotive and engineering industries

## 制造金刚石工具技术的比较 / Comparison of manufacturing technologies for diamond tools













电镀的/Galvanik

烧结/Sinter

真空扩散钎焊/VDW

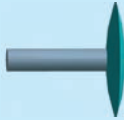

## 产品概述 Produkt overview

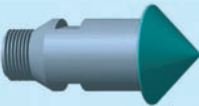
商品 Item	形状 Shape	代码 Code	图纸 Image	应用 Application
金刚石销 Diamond pins	锥形 Cone	MD-P-C1-C		工业陶瓷 Technical ceramics 施工 Construction 玻璃工业 Glass industry 珠宝工业 Jewelry 加工工业 Processing industry 石材行业 Stone industry
	倒锥形 Inversed Cone	MD-P-C1I-C		
	圆端锥形 Rounded End Cone	MD-P-C1R-C		
	截锥体 Truncated Cone	MD-P-C1T-C		
	圆柱 Cylinder	MD-P-C3-C		
	圆端缸形 Rounded End Cylinder	MD-P-C3R-C		
	盘形 Disc	MD-P-D-C		
	火焰形 Flame	MD-P-F-C		
	镜头形 Lens	MD-P-L-C		
	球形 Sphere	MD-P-S1-C		
校正销 Correction pins	圆柱 Cylinder	MD-CP-C3-C		加工工业 Processing industry
金刚石扩孔磨头 Diamond countersinks	锥形 Cone	MD-C-C1-T		施工 Construction 玻璃工业 Glass industry



商品 Item	形状 Shape	代码 Code	图纸 Image	应用 Application
金刚石扩孔磨头 Diamond countersinks	锥形 Cone	MD-C-C1-C		施工 Construction  玻璃工业 Glass industry
		MD-C-C1-U		
	圆台形 Truncated Cone	MD-C-C1T-T		
	MD-C-C1T-C			
	MD-C-C1T-U			
金刚石镗钻 Diamond drilling bits	取芯 Core	MD-DB-C2-T		施工 Construction  玻璃工业 Glass Industry
		MD-DB-C2-C		
		MD-DB-C2-U		
	马蹄形 Horseshoe	MD-DB-H-T		石材行业 Stone Industry
		MD-DB-H-C		
金刚石取芯扩孔钻头 Diamond countersink core bits	可调 Adjustable	MD-CDB-A1C2-T		玻璃工业 Glass industry
		MD-CDB-A1C2-C		
	MD-CDB-A1C2-U			
	整体 Monoblock	MD-CDB-MC2-T		
MD-CDB-MC2-T*				



商品 Item	形状 Shape	代码 Code	图纸 Image	应用 Application
金刚石取芯扩孔钻头 Diamond countersink core bits	螺旋槽 Spiral grooves	MD-MC-S2-T		工业陶瓷 Technical ceramics
	螺旋槽 Spiral grooves	MD-MC-S2-C		
	圆柱体 Cylindrical	MD-MC-C3-T		石材行业 Stone industry
	直槽 Straight Grooves	MD-MC-S3-T		复合物 Compound
	圆柱体 Cylindrical	MD-MC-C3-C		
金刚石断面研磨头 Diamond profile bits	圆形 Rounded	MD-PB-RI-T		工业陶瓷 Technical ceramics
		MD-PB-RI-C		施工 Construction
	梯形 Trapezoidal	MD-PB-T-T		玻璃工业 Glass Industry
		MD-PB-T-C		石材行业 Stone Industry
金刚石轮 Diamond wheels	外部的角 External angular	MD-W-A2E		工业陶瓷 Technical ceramics
	圆盘 Disc	MD-W-D		
	外圆形 External rounded	MD-W-RE		施工 Construction
	内圆形 Internal rounded	MD-W-RI		玻璃工业 Glass Industry
	值的 Straight	MD-W-S3		石材行业 Stone Industry
	梯形 Trapezoidal	MD-W-T		

## 锥形 / CONE

MD-P-C1-C

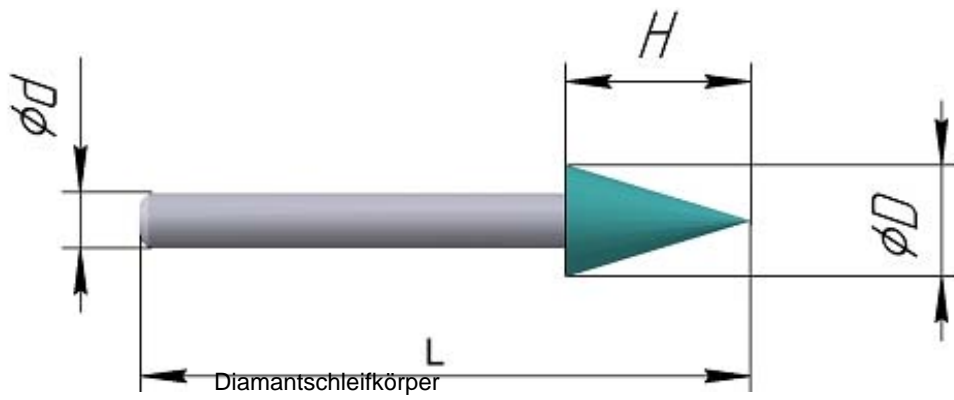

ØD x H mm	Ød, mm					
	Ø1,6	Ø2,35	Ø3,0	Ø4,0	Ø5,0	Ø6,0
2,7x7,2	●	●	●	●	—	—
4,6x11,0	—	●	●	●	●	●
5,0x12,0	—	●	●	●	●	●
5,0x14,0	—	●	●	●	●	●
5,5x13,0	—	●	●	●	●	●
6,0x13,0	—	●	●	●	●	●
6,0x15,0	—	—	●	●	●	●
7,0x10,0	—	—	●	●	●	●
12,0x6,0	—	—	●	●	●	●

定货代码: MD-P-C1-C ØD \_\_\_\_ x H \_\_\_\_ -Ød \_\_\_\_



倒锥形 / Inversed Cone

MD-P-C1I-C

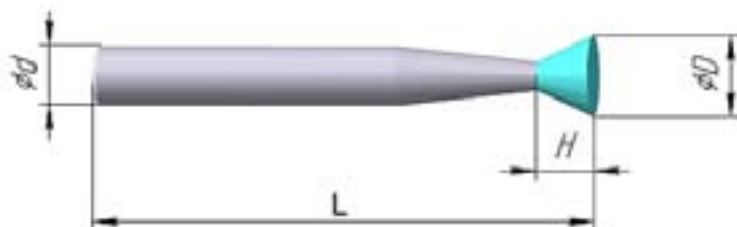

ØD x H mm	Ød, mm					
	Ø1,6	Ø2,35	Ø3,0	Ø4,0	Ø5,0	Ø6,0
1,4x2,0	●	●	—	—	—	—
1,5x6,0	●	●	—	—	—	—
1,6x1,5	—	●	—	—	—	—
1,6x4,0	●	●	—	—	—	—
1,8x0,7	—	●	—	—	—	—
1,8x1,5	—	●	—	—	—	—
2,1x1,9	●	●	—	—	—	—
2,3x0,8	—	●	—	—	—	—
2,5x2,5	—	●	—	—	—	—
3,2x2,8	—	●	—	—	—	—
3,7x9,0	—	●	—	—	—	—
4,0x2,0	●	●	—	—	—	—
5,2x3,2	—	●	—	—	—	—
6,0x5,0	—	●	●	●	—	—
7,0x5,0	—	●	●	●	●	●
8,0x4,0	—	●	●	●	●	●
11,0x6,0	—	●	—	●	●	●
11,0x2,5	—	●	—	●	●	●
16,0x9,0	—	—	—	●	●	●

定货代码: MD-P-C1I-C ØD \_\_\_\_ x H \_\_\_\_ - Ød \_\_\_\_

## 圆端锥形 / Rounded End Cone

MD-P-C1R-C

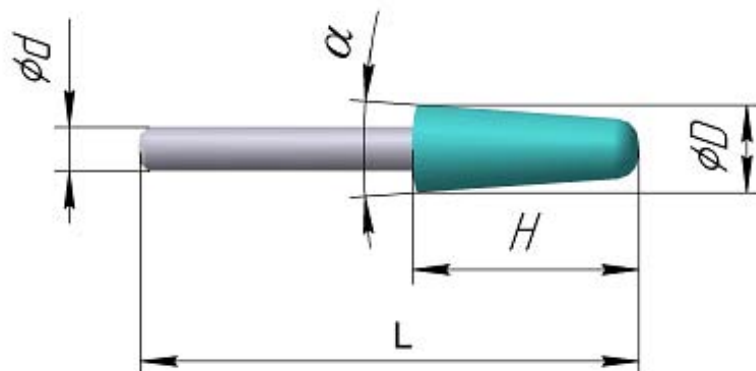

$\phi D \times H$ mm	$\phi d$ , mm					
	$\phi 1,6$	$\phi 2,35$	$\phi 3,0$	$\phi 4,0$	$\phi 5,0$	$\phi 6,0$
1,6x10,0	●	●	●	—	—	—
1,8x5,0	●	●	●	—	—	—
1,8x8,0	●	●	●	—	—	—
1,8x12,0	●	●	●	—	—	—
2,3x11,5	●	●	●	—	—	—
2,5x10,0	●	●	●	—	—	—
3,1x13,0	●	●	●	●	●	●
3,2x11,0	●	●	●	●	●	●
3,3x10,0	—	●	●	●	●	●
4,0x8,0	—	●	●	●	●	●
4,0x10,0	—	●	●	●	●	●
4,8x12,0	—	●	●	●	●	●
5,0x10,0	—	●	●	●	●	●
5,0x14,0	—	●	●	●	●	●
5,5x13,0	—	●	●	●	●	●
6,0x13,0	—	●	●	●	●	●
6,0x15,0	—	—	●	●	●	●
7,0x12,0	—	●	●	●	●	●
8,0x16,0	—	—	—	—	—	●
15,0x25,0	—	—	—	—	—	●

定货代码: MD-P-C1R-C  $\phi D$ \_\_\_\_ x H\_\_\_\_ -  $\phi d$ \_\_\_\_

截锥体 / Truncated Cone

MD-P-C1T-C

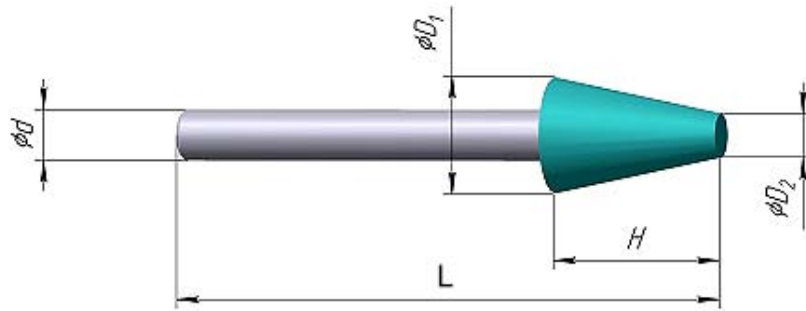

$\phi D_1 / \phi D_2 \times H$ mm	$\phi d$ , mm					
	$\phi 1,6$	$\phi 2,35$	$\phi 3,0$	$\phi 4,0$	$\phi 5,0$	$\phi 6,0$
1,5/0,7x6,0	●	●	—	—	—	—
3,0/1,8x9,0	—	●	●	—	—	—
4,5/1,3x6,0	—	—	●	—	—	—
5,0/3,0x10,3	—	●	●	—	—	—
6,0/2,8x6,0	—	—	●	●	●	●
9,0/5,0x2,0	—	—	●	●	●	●
10,0/5,0x20,0	—	—	●	●	●	●
12,0/5,0x17,0	—	—	●	●	●	●
12,0/7,0x20,0	—	—	●	●	●	●

定货代码: MD-P-C1T-C  $\phi D_1 / \phi D_2$ \_\_\_\_/\_\_\_\_ x H\_\_\_\_ -  $\phi d$ \_\_\_\_

## 圆柱 / Cylinder

MD-P-C3-C

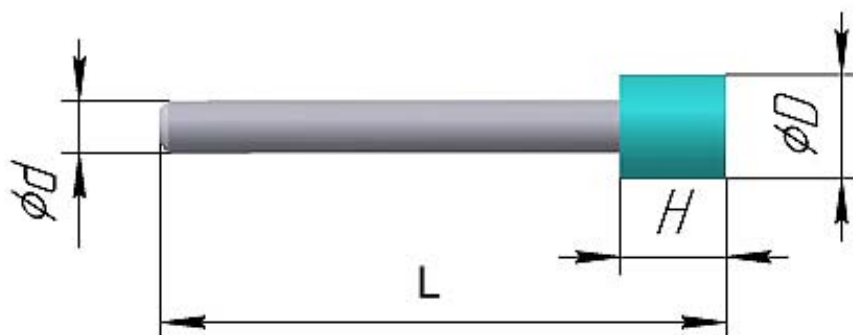

ØD x H mm	Ød, mm					
	Ø1,6	Ø2,35	Ø3,0	Ø4,0	Ø5,0	Ø6,0
1,4x4,0÷7,0	●	●	●	—	—	—
1,6x6,0÷9,0	●	●	●	—	—	—
1,7x6,0÷9,0	—	●	●	—	—	—
1,8x6,0÷9,0	●	●	●	—	—	—
3,0x5,0÷7,0	—	●	●	●	●	●
3,0x7,0÷10,0	—	●	●	●	●	●
3,5x5,0÷7,0	—	●	●	●	●	●
3,5x7,0÷10,0	—	●	●	●	●	●
4,0x5,0÷7,0	—	●	●	●	●	●
4,0x7,0÷10,0	—	●	●	●	●	●
4,0x10,0÷12,0	—	●	●	●	●	●
4,0x12,0÷15,0	—	●	●	●	●	●
4,5x5,0÷7,0	—	●	●	●	●	●
4,5x7,0÷10,0	—	●	●	●	●	●
4,5x10,0÷12,0	—	●	●	●	●	●
4,5x12,0÷15,0	—	●	●	●	●	●
5,0x5,0÷7,0	—	●	●	●	●	●
5,0x7,0÷10,0	—	●	●	●	●	●
5,0x10,0÷12,0	—	●	●	●	●	●
5,0x12,0÷15,0	—	●	●	●	●	●
6,0x5,0÷7,0	—	●	●	●	●	●
6,0x7,0÷10,0	—	—	●	●	●	●

圆柱 / Cylinder

MD-P-C3-C

ØD x H mm	Ød, mm					
	Ø1,6	Ø2,35	Ø3,0	Ø4,0	Ø5,0	Ø6,0
6,0x10,0 ÷ 12,0	—	—	●	●	●	●
6,0x12,0 ÷ 15,0	—	—	●	●	●	●
6,5x5,0 ÷ 7,0	—	—	●	●	●	●
6,5x7,0 ÷ 10,0	—	—	●	●	●	●
6,5x10,0 ÷ 12,0	—	—	●	●	●	●
6,5x12,0 ÷ 15,0	—	—	●	●	●	●
7,0x5,0 ÷ 7,0	—	—	—	●	●	●
7,0x7,0 ÷ 10,0	—	—	—	●	●	●
7,0x10,0 ÷ 12,0	—	—	—	●	●	●
7,0x12,0 ÷ 15,0	—	—	—	●	●	●
8,0x10,0 ÷ 12,0	—	—	—	●	●	●
8,0x12,0 ÷ 15,0	—	—	—	●	●	●
8,0x15,0 ÷ 18,0	—	—	—	●	●	●
8,0x18,0 ÷ 20,0	—	—	—	●	●	●
10,0x10,0 ÷ 12,0	—	—	—	●	●	●
10,0x12,0 ÷ 15,0	—	—	—	●	●	●
10,0x15,0 ÷ 18,0	—	—	—	●	●	●
10,0x18,0 ÷ 20,0	—	—	—	●	●	●

定货代码: MD-P-C3-C ØD \_\_\_\_ x H \_\_\_\_ - Ød \_\_\_\_

## 圆端缸形 / Rounded End Cylinder

MD-P-C3R-C

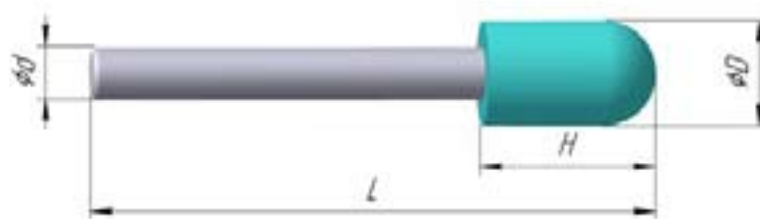

ØD x H mm	Ød, mm					
	Ø1,6	Ø2,35	Ø3,0	Ø4,0	Ø5,0	Ø6,0
1,6x(8,0÷10,0)	●	●	●	●	●	●
2,0x(10,0÷15,0)	—	—	●	●	●	●
2,5x12,0	—	●	—	—	—	—
3,0x8,5	—	●	—	—	—	—
3,0x(12,0÷15,0)	—	—	●	—	—	—
4,0x8,0	—	—	—	—	—	●
4,0x10,0	—	●	●	●	●	●
5,0x10,0	—	●	●	●	●	●
6,0x(12,0÷15,0)	—	—	●	●	●	●
6,3x12,0	—	●	●	●	●	●
10,0x(8,0÷20,0)	—	—	●	●	●	●
12,0x20,0	—	—	—	—	—	●
15,0x20,0	—	—	—	—	—	●

定货代码: MD-P-C3R-C ØD\_\_\_\_ x H\_\_\_\_ - Ød\_\_\_\_

轮 / Disc

MD-P-D-C

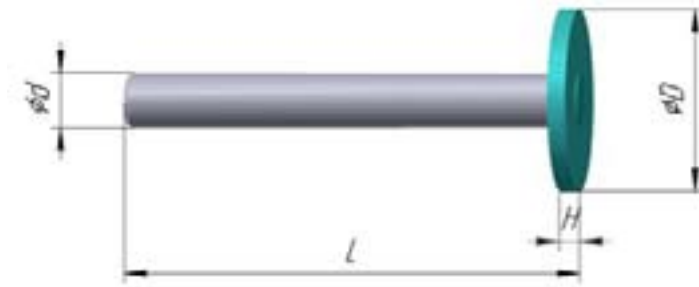

ØD x H mm	Ød, mm					
	Ø1,6	Ø2,35	Ø3,0	Ø4,0	Ø5,0	Ø6,0
(2,8÷4,6)x0,5	●	—	—	—	—	—
4,2x1,7	●	●	●	—	—	—
5,0x0,3	●	●	●	—	—	—
6,0x0,3	—	●	●	—	—	—
6,3x0,7	—	●	●	—	—	—
8,0x(0,4÷1,0)	—	●	●	●	●	—
8,0x(2,0÷3,0)	—	●	●	●	●	●
1,0x(0,3÷1,0)	—	●	●	●	●	●
10,0x3,0	—	●	●	●	●	●
11,0x1,6	—	●	●	●	●	●
13,0x(3,0÷5,0)	—	●	●	●	●	●
14,0x0,6	—	●	●	●	●	●
15,0x3,0	—	●	●	●	●	●
16,0x0,3	—	●	●	●	●	●
20,0x2,0	—	●	●	●	●	●
22,0x(0,4÷0,6)	—	●	●	●	●	●
25,0x(0,8÷1,0)	—	●	●	●	●	●
25,0x1,8	—	●	●	●	●	●
30,0x(1,0÷5,0)	—	●	●	●	●	●
32,0x0,6	—	●	●	●	●	●
35,0x2,5	—	—	●	●	●	●
40,0x(0,6÷1,0)	—	●	●	●	●	●

定货代码: MD-P-D-C ØD \_\_\_\_ x H \_\_\_\_ - Ød \_\_\_\_

## 火焰形 / Flame

MD-P-F-C

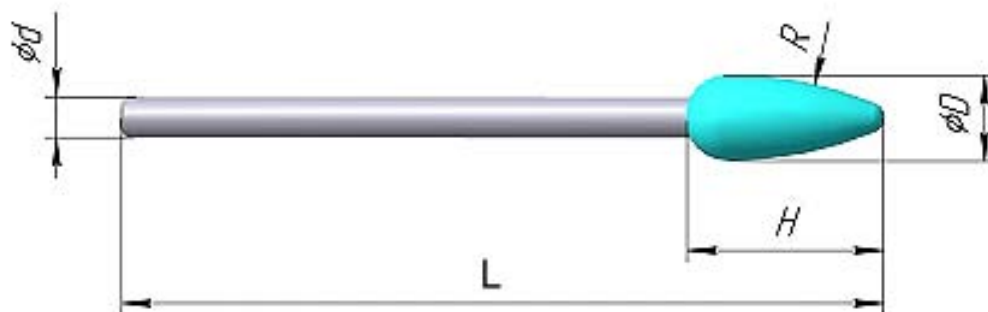

$\phi D \times H$ mm	$\phi d$ , mm					
	$\phi 1,6$	$\phi 2,35$	$\phi 3,0$	$\phi 4,0$	$\phi 5,0$	$\phi 6,0$
3,0x7,5	• R14,5	• R14,5	• R14,5	• R14,5	• R14,5	• R14,5
3,0x9,5	• R12,8	• R12,8	—	—	—	—
5,0x9,0	—	• R22,0	—	—	—	—
5,0x11,0	—	• R22,0	—	—	—	—
5,0x15,4	—	• R18,0	—	—	—	—
5,6x13,8	—	• R15,0	—	—	—	—
6,0x12,5	—	• R16,6	—	—	—	—
6,0x13,0	—	• R39,0	—	—	—	—
7,8x15,0	—	• R14,0	—	—	—	—
10,0x20,0	—	• R22,1	• R22,1	• R22,1	• R22,1	• R22,1

定货代码：MD-P-F-C  $\phi D$ \_\_\_\_ x H\_\_\_\_ -  $\phi d$ \_\_\_\_



镜头形 / Lens

MD-P-L-C

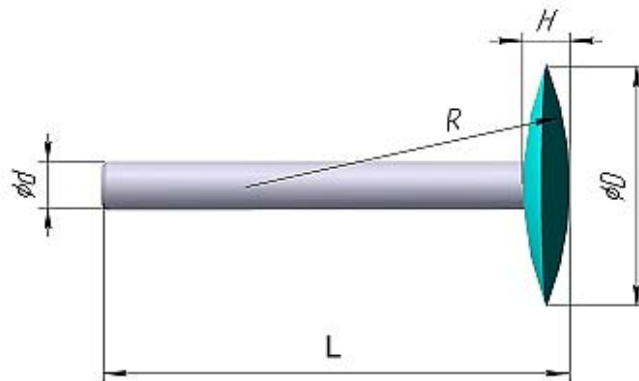

ØD x H mm	Ød, mm					
	Ø1,6	Ø2,35	Ø3,0	Ø4,0	Ø5,0	Ø6,0
2,1x0,7	●	●	—	—	—	—
4,0x1,0	●	●	—	—	—	—
5,0x1,4	●	●	●	—	—	—
6,0x08,7	●	●	●	●	●	●
8,0x2,0	—	●	●	●	●	●
11,2x2,0	—	●	●	●	●	●
30,0x8,0	—	—	—	—	●	●
50,0x12,0	—	—	—	—	●	●

定货代码：MD-P-L-C ØD\_\_\_\_ x H\_\_\_\_ - Ød\_\_\_\_

## 球形 / Sphere

MD-P-S1-C

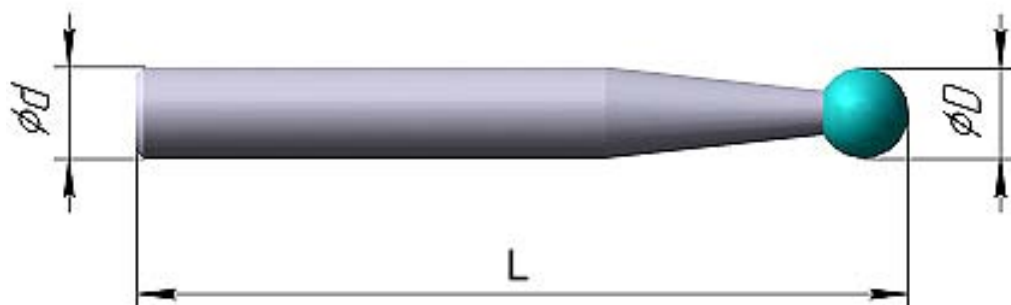

ØD mm	Ød, mm					
	Ø1,6	Ø2,35	Ø3,0	Ø4,0	Ø5,0	Ø6,0
1,4	●	●	—	—	—	—
1,6	●	●	—	—	—	—
1,8	●	●	—	—	—	—
2,0	●	●	—	—	—	—
2,3	●	●	—	—	—	—
2,5	●	●	—	—	—	—
2,9	●	●	●	●	●	●
3,5	●	●	●	●	●	●
5,0	—	●	●	●	●	●
6,0	—	●	●	●	●	●
6,3	—	●	●	●	●	●
7,0	—	—	●	●	●	●
8,0	—	—	●	●	●	●
9,0	—	—	●	●	●	●
9,5	—	—	●	●	●	●
10,0	—	—	●	●	●	●
11,0	—	—	●	●	●	●

定货代码：MD-P-S1-C ØD\_\_\_\_ - Ød\_\_\_\_

## 圆柱 / Cylinder

## MB-CP-C3-C

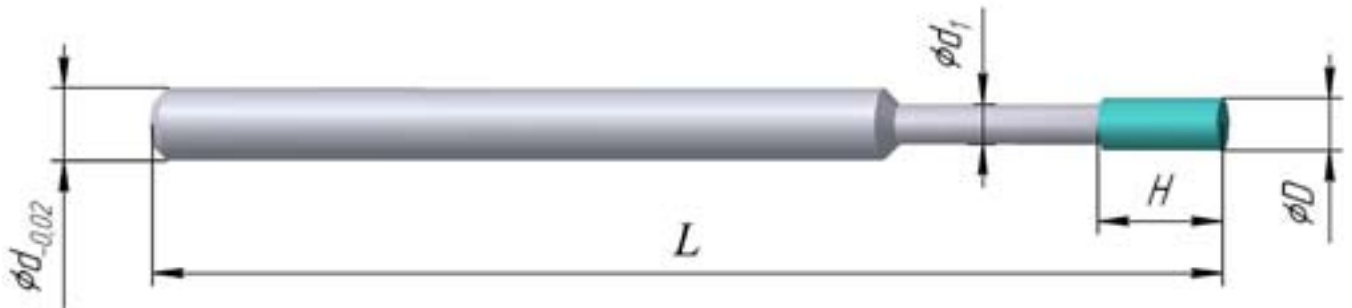

代码	ØD, mm	H, mm	Ød, mm	Ød <sub>1</sub> , mm	l, mm	L, mm
MB-CP-C3-C	1,0	2,0	3,0	0,8	6,0	50
MB-CP-C3-C	1,25	2,5		1,0	7,0	
MB-CP-C3-C	1,5	3,0		1,2	9,0	
MB-CP-C3-C	1,75	3,5		1,4	10,0	
MB-CP-C3-C	2,0	4,0		1,6	12,0	
MB-CP-C3-C	2,25	4,5		1,8	13,0	
MB-CP-C3-C	2,5	5,0		2,0	15,0	
MB-CP-C3-C	3,0	4,0		2,6	18,0	
MB-CP-C3-C	3,5	4,5		3,0		
MB-CP-C3-C	4,0	5,0		3,0		
MB-CP-C3-C	4,5	5,0	4,0	4,0		60
MB-CP-C3-C	5,0	6,0				
MB-CP-C3-C	5,5	6,0	5,0	5,0		70
MB-CP-C3-C	6,0	7,0				
MB-CP-C3-C	6,5	8,0	6,0	6,0		80
MB-CP-C3-C	7,0	8,0				
MB-CP-C3-C	9,0	9,0	8,0	8,0		90
MB-CP-C3-C	11,0	10,0				

定货代码: MB-CP-C3-C ØD\_\_\_\_ x H\_\_\_\_

## 锥体 / CONE

MD-C-C1-C

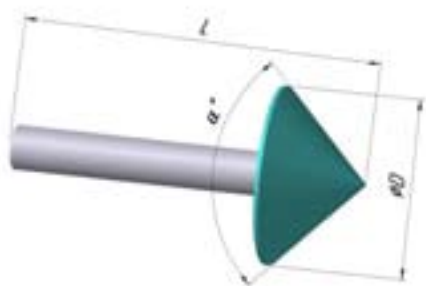

MD-C-C1-T

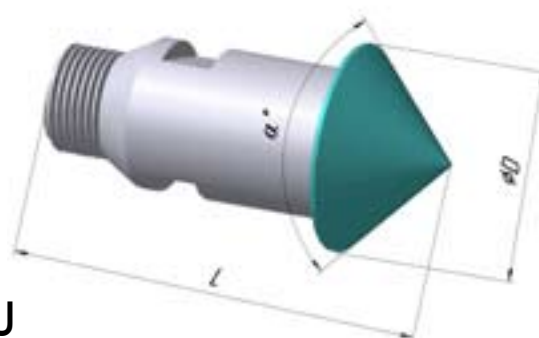

MD-C-C1-U

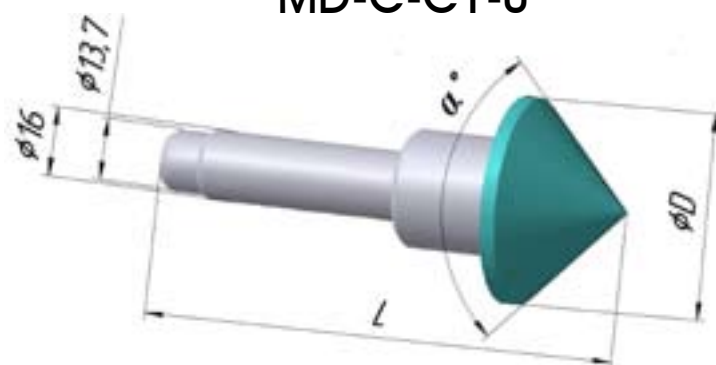

Code/代码	ØD, mm	α°	L, mm	Ød, mm
MD-C-C1-C	6	90	35	2,35
MD-C-C1-C	12	90	54	6,0
MD-C-C1-C	12	90	60	8,0
MD-C-C1-C	14	90	44	6,0
MD-C-C1-C	14	90	44	10,0
MD-C-C1-C	15	120	52	6,0
MD-C-C1-C	16	90	44	6,0
MD-C-C1-C	40	90	70	6,0
MD-C-C1-U	40	90	115	16,0
MD-C-C1-C	40	90	50	8,0
MD-C-C1-C	40	90	50	12,0
MD-C-C1-T	40	90	71	G1/2-A
MD-C-C1-C	66	110	152	10,0

MD-C-C1-C若没有上面表格的尺寸和连接头，可根据客户的要求定做

The special points MD-C-C1-C of other sizes and connections are available upon customer's request

\* 以上任意ØD 30mm作为特殊定单

\* Any order above 30mm of ØD is considered as special order

定货代码: MD-C-C1-C

ØD\_\_ α°\_\_ - L\_\_ - Ød\_\_

定货代码: MD-C-C1-T

ØD\_\_ α°\_\_ - L\_\_

定货代码: MD-C-C1-U

ØD\_\_ α°\_\_ - L\_\_

## 截锥体 / TRUNCATED CONE

MD-C-C1T-C

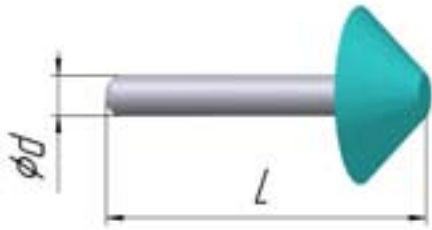

MD-C-C1T-T

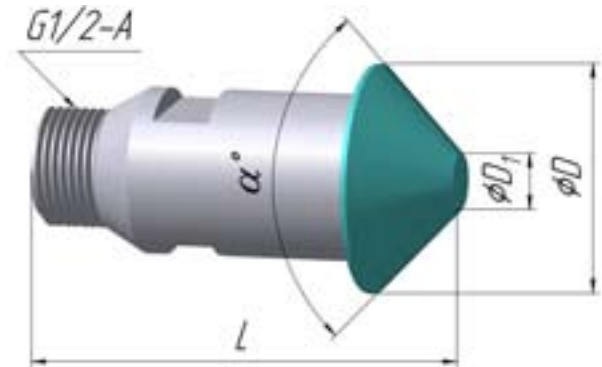

MD-C-C1T-U



CODE / 代码	$\phi D$ , mm	$\phi D_1$ , mm	$\alpha^\circ$	L, mm	$\phi d$ , mm
MD-C-C1T-C	26	10	90	46	6,0
MD-C-C1T-C	26	10	90	44	10,0
MD-C-C1T-T	26	10	90	70	G1/2-A
MD-C-C1T-T	40	10	90	75	G1/2-A
MD-C-C1T-U	40	10	90	116	16,0
MD-C-C1T-T	41	8	90	75	G1/2-A
MD-C-C1T-T	50	20	90	75	G1/2-A
MD-C-C1T-T	70	35	90	75	G1/2-A
MD-C-C1T-U	70	35	90	116	16,0

MD-C-C1T-C 若没有上面表格的尺寸和连接头，可根据客户的要求定做

The special points MD-C-C1T-C of other sizes and connections are available upon customer's request

\* 以上任意 $\phi D$  30mm作为特殊定单

\* Any order above 30mm of  $\phi D$  is considered as special order

定货代码: MD-C-C1T-C

$\phi D/\phi D_1$   $\alpha^\circ$  - L -  $\phi d$

定货代码: MD-C-C1T-T

$\phi D/\phi D_1$   $\alpha^\circ$  - L

定货代码: MD-C-C1T-U

$\phi D/\phi D_1$   $\alpha^\circ$  - L

## 取芯 / CORE

## MD-DB-C2-T

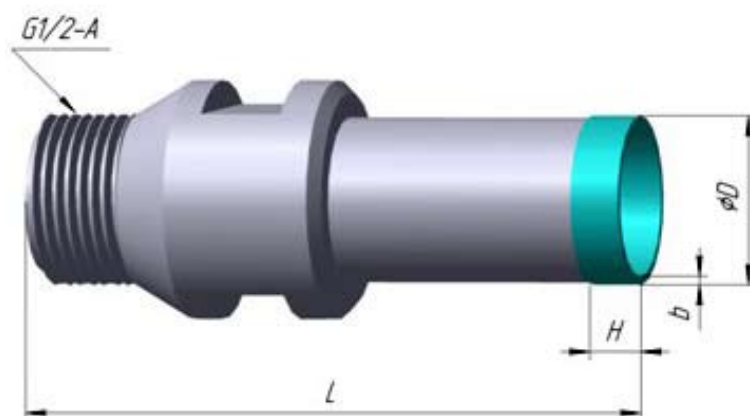

CODE / 代码	ØD, mm	b, mm	H, mm	L, mm	
MD-DB-C2-T	3,0	0,8	5,0	75,0	
MD-DB-C2-T	3,5		4,0	75,0	
MD-DB-C2-T	4,0		6,0		75,0
MD-DB-C2-T	4,0				95,0
MD-DB-C2-T	4,5				75,0
MD-DB-C2-T	5,0				95,0
MD-DB-C2-T	5,0				75,0
MD-DB-C2-T	5,6				75,0
MD-DB-C2-T	6,0				75,0
MD-DB-C2-T	6,0				95,0
MD-DB-C2-T	6,5				75,0
MD-DB-C2-T	7,0				75,0
MD-DB-C2-T	8,0				75,0
MD-DB-C2-T	8,0				95,0
MD-DB-C2-T	8,5				75,0
MD-DB-C2-T	9,0				75,0
MD-DB-C2-T	10,0				75,0
MD-DB-C2-T	10,0				95,0
MD-DB-C2-T	10,5			75,0	
MD-DB-C2-T	11,0			75,0	
MD-DB-C2-T	11,3		75,0		
MD-DB-C2-T	11,5		75,0		
MD-DB-C2-T	12,0		75,0		
MD-DB-C2-T	12,0		95,0		
MD-DB-C2-T	12,5		75,0		
MD-DB-C2-T	13,0		75,0		
MD-DB-C2-T	14,0		75,0		
MD-DB-C2-T	14,0		95,0		
MD-DB-C2-T	15,0		75,0		
MD-DB-C2-T	16,0		75,0		

## MD-DB-C2-T

CODE / 代码	ØD, mm	b, mm	H, mm	L, mm	
MD-DB-C2-T	16,0	0,8	6,0	95,0	
MD-DB-C2-T	16,2			75,0	
MD-DB-C2-T	17,0			75,0	
MD-DB-C2-T	18,0			75,0	
MD-DB-C2-T	18,2			75,0	
MD-DB-C2-T	18,3			75,0	
MD-DB-C2-T	19,0			75,0	
MD-DB-C2-T	20,0			75,0	
MD-DB-C2-T	21,0			75,0	
MD-DB-C2-T	22,0			75,0	
MD-DB-C2-T	23,0			75,0	
MD-DB-C2-T	24,0			75,0	
MD-DB-C2-T	24,5			75,0	
MD-DB-C2-T	25,0			75,0	
MD-DB-C2-T	25,0			95,0	
MD-DB-C2-T	25,2			75,0	
MD-DB-C2-T	26,0			75,0	
MD-DB-C2-T	26,0			95,0	
MD-DB-C2-T	26,2			75,0	
MD-DB-C2-T	26,2			95,0	
MD-DB-C2-T	26,4			75,0	
MD-DB-C2-T	27,0			75,0	
MD-DB-C2-T	27,0			95,0	
MD-DB-C2-T	28,0			75,0	
MD-DB-C2-T	28,2			75,0	
MD-DB-C2-T	28,3			75,0	
MD-DB-C2-T	29,0			75,0	
MD-DB-C2-T	30,0			75,0	
MD-DB-C2-T	31,0			1,0	75,0
MD-DB-C2-T	32,0				75,0
MD-DB-C2-T	33,0	75,0			
MD-DB-C2-T	34,0	75,0			
MD-DB-C2-T	35,0	75,0			
MD-DB-C2-T	36,0	75,0			
MD-DB-C2-T	37,0	75,0			
MD-DB-C2-T	37,2	75,0			
MD-DB-C2-T	38,0	75,0			
MD-DB-C2-T	39,0	75,0			
MD-DB-C2-T	39,2	75,0			
MD-DB-C2-T	40,0	75,0			

## MD-DB-C2-T

CODE / 代码	ØD, mm	b, mm	H, mm	L, mm
MD-DB-C2-T	41,0			75,0
MD-DB-C2-T	42,0			75,0
MD-DB-C2-T	43,0			75,0
MD-DB-C2-T	44,0			75,0
MD-DB-C2-T	45,0			75,0
MD-DB-C2-T	46,0			75,0
MD-DB-C2-T	47,0	1,0	6,0	75,0
MD-DB-C2-T	48,0			75,0
MD-DB-C2-T	49,0			75,0
MD-DB-C2-T	50,0			75,0
MD-DB-C2-T	50,0			95,0
MD-DB-C2-T	52,0			75,0
MD-DB-C2-T	53,0			75,0
MD-DB-C2-T	55,0			75,0
MD-DB-C2-T	60,0			75,0
MD-DB-C2-T	62,0			75,0
MD-DB-C2-T	65,0	1,2		75,0
MD-DB-C2-T	70,0			75,0
MD-DB-C2-T	70,0			75,0
MD-DB-C2-T	70,0			95,0

MD-DB-C2-T 若没有上面表格的尺寸和连接头，可根据客户的要求定做

The special points MD-DB-C2-T of other sizes and connections are available upon customer's request

\* 以上任意ØD 30mm作为特殊定单

\* Any order above 30mm of ØD is considered as special order

定货代码: MD-DB-C2-T      ØD \_\_\_ x b \_\_\_ - H \_\_\_ - L \_\_\_



## 取芯 / CORE

### MD-DB-C2-C

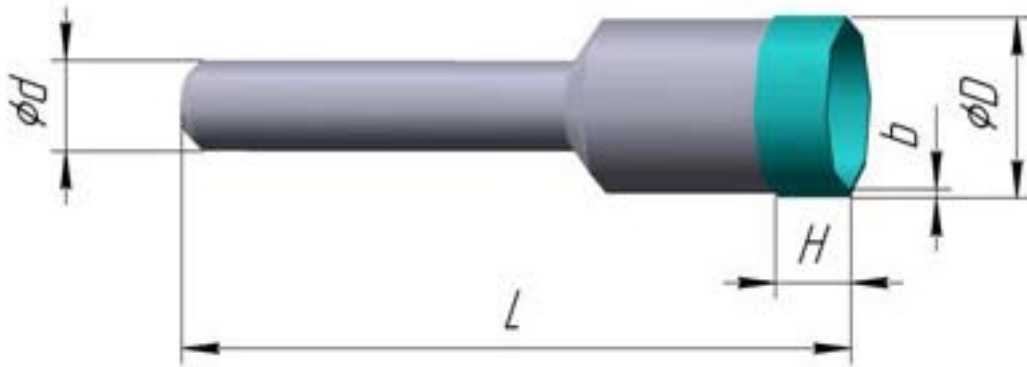

CODE/代码	$\phi D$ , mm	b, mm	H, mm	L, mm	$\phi d$
MD-DB-C2-C	3,0	0,7	5,0	46,0	6,0
MD-DB-C2-C	3,2	0,7	5,0	46,0	6,0
MD-DB-C2-C	3,5	0,8	5,0	46,0	6,0
MD-DB-C2-C	4,0	0,8	6,0	65,0	6,0
MD-DB-C2-C	5,0	0,8	6,0	46,0	6,0
MD-DB-C2-C	5,0	0,8	6,0	65,0	6,0
MD-DB-C2-C	5,5	0,9	5,0	60,0	6,0
MD-DB-C2-C	6,0	0,8	5,0	46,0	6,0
MD-DB-C2-C	6,0	0,8	6,0	65,0	6,0
MD-DB-C2-C	6,2	0,8	5,0	46,0	6,0
MD-DB-C2-C	7,0	0,8	5,0	46,0	6,0
MD-DB-C2-C	7,5	0,8	5,0	46,0	6,0
MD-DB-C2-C	8,0	0,8	6,0	46,0	6,0
MD-DB-C2-C	8,0	0,8	6,0	65,0	6,0
MD-DB-C2-C	9,0	0,8	6,0	46,0	6,0
MD-DB-C2-C	9,0	0,8	6,0	65,0	6,0
MD-DB-C2-C	9,5	0,8	5,0	46,0	6,0
MD-DB-C2-C	10,0	0,8	6,0	65,0	6,0
MD-DB-C2-C	10,0	0,7	5,0	46,0	6,0
MD-DB-C2-C	10,5	0,8	5,0	46,0	6,0
MD-DB-C2-C	11,0	0,8	5,0	46,0	6,0
MD-DB-C2-C	12,0	0,8	5,0	46,0	6,0
MD-DB-C2-C	13,0	0,8	5,0	46,0	6,0
MD-DB-C2-C	14,0	0,8	6,0	46,0	6,0
MD-DB-C2-C	15,0	0,8	6,0	46,0	6,0
MD-DB-C2-C	16,0	0,8	5,0	46,0	6,0
MD-DB-C2-C	18,0	1,0	6,0	50,0	6,0
MD-DB-C2-C	26,0	1,0	6,0	44,0	10,0
MD-DB-C2-C	26,0	1,0	6,0	50,0	6,0
MD-DB-C2-C	26,2	1,0	6,0	44,0	6,0

## MD-DB-C2-C

code/代码	ØD, mm	b, mm	H, mm	L, mm	Ød
MD-DB-C2-C	26,2	0,8	6,0	44,0	8,0
MD-DB-C2-C	27,0	1,0	6,0	44,0	6,0
MD-DB-C2-C	28,0	1,0	6,0	44,0	6,0
MD-DB-C2-C	35,0	1,0	6,0	44,0	8,0
MD-DB-C2-C	35,0	1,0	6,0	50,0	10,0
MD-DB-C2-C	39,0	1,0	6,0	70,0	10,0
MD-DB-C2-C	40,0	1,0	6,0	50,0	10,0
MD-DB-C2-C	50,0	1,0	6,0	50,0	10,0

MD-DB-C2-C 若没有上面表格的尺寸和连接头，可根据客户的要求定做

The special points MD-DB-C2-C of other sizes and connections are available upon customer's request

\* 以上任意ØD 30mm作为特殊定单

\* Any order above 30mm of ØD is considered as special order

定货代码: MD-DB-C2-C      ØD\_\_x b\_\_ - H\_\_ - L\_\_ - Ød\_\_

## 取芯 / CORE

### MD-DB-C2-C

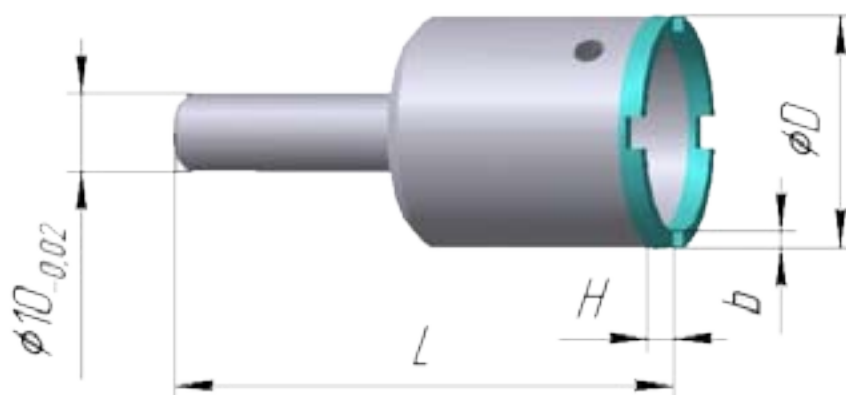

CODE/代码	ØD, mm	b, mm	H, mm	L, mm
MD-DB-C2-C	3,0	1,2	2,5	67,5
MD-DB-C2-C	4,0			
MD-DB-C2-C	5,0	1,4	3,0	
MD-DB-C2-C	6,0			
MD-DB-C2-C	7,0			
MD-DB-C2-C	8,0			
MD-DB-C2-C	9,0			
MD-DB-C2-C	10,0			
MD-DB-C2-C	11,0			
MD-DB-C2-C	12,0			
MD-DB-C2-C	13,0			
MD-DB-C2-C	14,0			
MD-DB-C2-C	15,0	2,5		
MD-DB-C2-C	16,0			
MD-DB-C2-C	17,0			
MD-DB-C2-C	18,0			
MD-DB-C2-C	19,0			
MD-DB-C2-C	20,0			
MD-DB-C2-C	21,0			
MD-DB-C2-C	22,0			
MD-DB-C2-C	23,0			
MD-DB-C2-C	24,0			
MD-DB-C2-C	25,0			
MD-DB-C2-C	26,0			
MD-DB-C2-C	27,0			
MD-DB-C2-C	28,0			
MD-DB-C2-C	29,0			
MD-DB-C2-C	30,0			
MD-DB-C2-C	31,0			
MD-DB-C2-C	32,0			

## MD-DB-C2-C

CODE / 代码	ØD, mm	b, mm	H, mm	L, mm
MD-DB-C2-C	33,0	1,4	2,5	67,5
MD-DB-C2-C	34,0			
MD-DB-C2-C	35,0			
MD-DB-C2-C	36,0			
MD-DB-C2-C	37,0			
MD-DB-C2-C	38,0			
MD-DB-C2-C	39,0			
MD-DB-C2-C	40,0			
MD-DB-C2-C	41,0			
MD-DB-C2-C	42,0			
MD-DB-C2-C	43,0			
MD-DB-C2-C	44,0			
MD-DB-C2-C	45,0			
MD-DB-C2-C	50,0			
MD-DB-C2-C	55,0			
MD-DB-C2-C	60,0			
MD-DB-C2-C	63,0			
MD-DB-C2-C	65,0			
MD-DB-C2-C	68,0			
MD-DB-C2-C	70,0			
MD-DB-C2-C	75,0			

MD-DB-C2-C 若没有上面表格的尺寸和连接头，可根据客户的要求定做

The special points MD-DB-C2-C of other sizes and connections are available upon customer's request

\* 以上任意ØD 30mm作为特殊定单

\* Any order above 30mm of ØD is considered as special order

定货代码: MD-DB-C2-C      ØD\_\_x b\_\_ – H\_\_ – L\_\_

## 取芯 / CORE

### MD-DB-C2-U

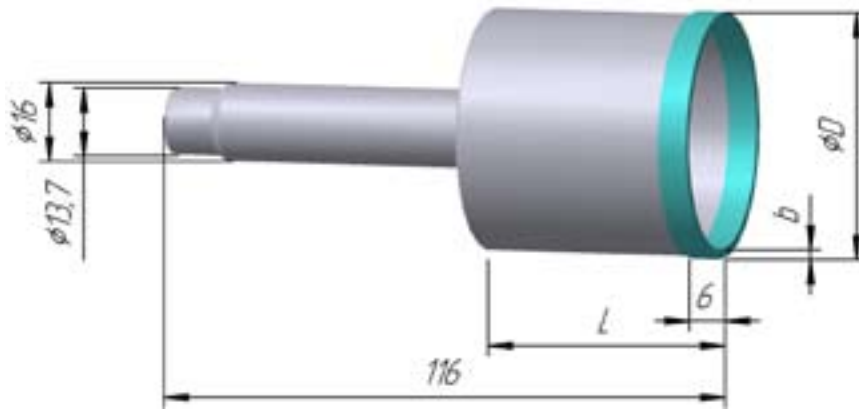

CODE / 代码	ØD, mm	b, mm	L, mm	H, mm
MD-DB-C2-U	3,0	0,8	28,0	6,0
MD-DB-C2-U	4,0			
MD-DB-C2-U	5,0			
MD-DB-C2-U	6,0			
MD-DB-C2-U	7,0			
MD-DB-C2-U	8,0			
MD-DB-C2-U	9,0			
MD-DB-C2-U	10,0			
MD-DB-C2-U	11,0			
MD-DB-C2-U	12,0			
MD-DB-C2-U	13,0			
MD-DB-C2-U	14,0			
MD-DB-C2-U	15,0			
MD-DB-C2-U	16,0			
MD-DB-C2-U	17,0			
MD-DB-C2-U	18,0			
MD-DB-C2-U	19,0			
MD-DB-C2-U	20,0			
MD-DB-C2-U	21,0			
MD-DB-C2-U	22,0			
MD-DB-C2-U	23,0			
MD-DB-C2-U	24,0			
MD-DB-C2-U	25,0			
MD-DB-C2-U	26,0			
MD-DB-C2-U	27,0			
MD-DB-C2-U	28,0			
MD-DB-C2-U	29,0			
MD-DB-C2-U	30,0			
MD-DB-C2-U	31,0			
MD-DB-C2-U	32,0			
MD-DB-C2-U		1,0	49,0	

## MD-DB-C2-U

CODE / 代码	ØD, mm	b, mm	L, mm	H, mm
MD-DB-C2-U	33,0	1,0	49,0	6,0
MD-DB-C2-U	34,0			
MD-DB-C2-U	35,0			
MD-DB-C2-U	36,0			
MD-DB-C2-U	37,0			
MD-DB-C2-U	38,0			
MD-DB-C2-U	39,0			
MD-DB-C2-U	40,0			
MD-DB-C2-U	41,0			
MD-DB-C2-U	42,0			
MD-DB-C2-U	43,0			
MD-DB-C2-U	44,0			
MD-DB-C2-U	45,0			
MD-DB-C2-U	46,0			
MD-DB-C2-U	47,0			
MD-DB-C2-U	48,0			
MD-DB-C2-U	49,0			
MD-DB-C2-U	50,0			
MD-DB-C2-U	52,0			
MD-DB-C2-U	53,0			
MD-DB-C2-U	55,0			
MD-DB-C2-U	60,0			
MD-DB-C2-U	65,0			

MD-DB-C2-U 若没有上面表格的尺寸和连接头，可根据客户的要求定做

The special points MD-DB-C2-U of other sizes and connections are available upon customer's request

\* 以上任意ØD 30mm作为特殊定单

\* Any order above 30mm of ØD is considered as special order

定货代码: MD-DB-C2-U      ØD\_\_x b\_\_ – H\_\_ – L\_\_

## 马蹄形 / HORSESHOE

### MD-DB-H-T

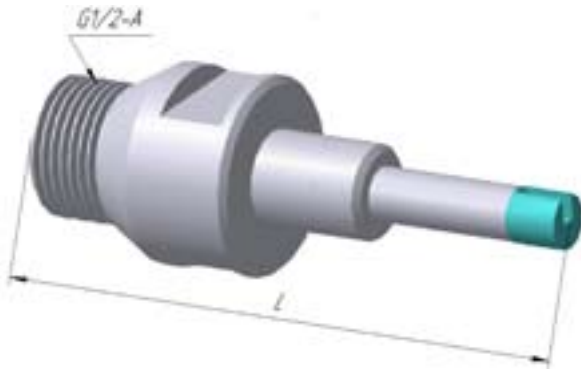

### MD-DB-H-C

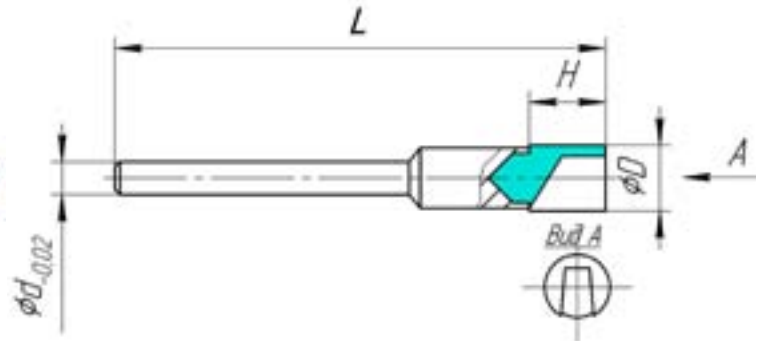

CODE/代码	ØD, mm	H, mm	L, mm	Ød
MD-DB-H-T	8,0	6,0	75,0	G1/2-A
MD-DB-H-C	1,8	3,0	25,0	1,6
MD-DB-H-C	1,8	6,0		
MD-DB-H-C	2,5	5,0	36,0	2,35
MD-DB-H-C	2,5	4,0	35,0	
MD-DB-H-C	3,0	4,0	35,0	
MD-DB-H-C	3,0	5,0	85,0	
MD-DB-H-C	3,5	5,0	45,0	
MD-DB-H-C	3,5	4,0	35,0	
MD-DB-H-C	4,0	4,0	35,0	
MD-DB-H-C	4,5	4,0	35,0	
MD-DB-H-C	5,0	4,0	35,0	
MD-DB-H-C	3,2	7,0	70,0	
MD-DB-H-C	3,2	7,0	45,0	
MD-DB-H-C	3,4	7,0	45,0	
MD-DB-H-C	3,5	5,0	85,0	
MD-DB-H-C	3,5	7,0	45,0	
MD-DB-H-C	3,6	7,0	45,0	
MD-DB-H-C	3,8	7,0	45,0	
MD-DB-H-C	4,0	5,0	60,0	
MD-DB-H-C	4,0	7,0	70,0	
MD-DB-H-C	4,2	7,0	45,0	
MD-DB-H-C	5,5	7,0	45,0	
MD-DB-H-C	5,0	7,0	45,0	
MD-DB-H-C	5,5	5,0	40,0	
MD-DB-H-C	3,0	7,0	45,0	6,0
MD-DB-H-C	3,4	7,0		
MD-DB-H-C	3,5	7,0		
MD-DB-H-C	3,6	7,0		
MD-DB-H-C	4,5	7,0		

## MD-DB-H-C

CODE/代码	ØD, mm	H, mm	L, mm	Ød
MD-DB-H-C	5,0	7,0	45,0	6,0
MD-DB-H-C	6,0	7,0		
MD-DB-H-C	8,0	6,0	60,0	8,0

MD-DB-H 若没有上面表格的尺寸和连接头，可根据客户的要求定做

The special points MD-DB-H of other sizes and connections are available upon customer's request

\* 以上任意ØD 30mm作为特殊定单

\* Any order above 30mm of ØD is considered as special order

定货代码: MD-DB-H-T  
定货代码: MD-DB-H-C

ØD \_\_\_ - H \_\_\_ - L \_\_\_  
ØD \_\_\_ - H \_\_\_ - L \_\_\_ - Ød \_\_\_



可调 / ADJUSTABLE

MD-CDB-A1C2-C



MD-CDB-A1C2-T



MD-CDB-A1C2-U

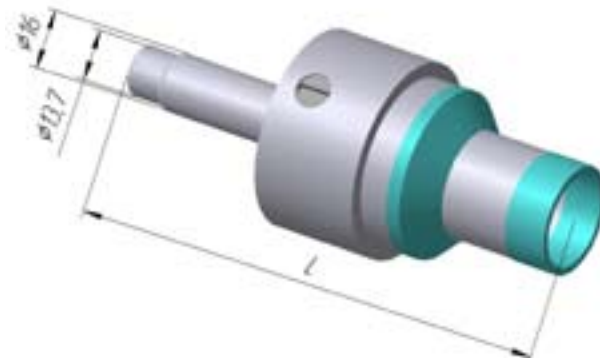

CODE / 代码	ØD, mm	ØD <sub>1</sub> , mm	b	H, mm	L, mm	Ød, mm
MD-CDB-A1C2-T	4,0	11,0	0,8	6,0	75,0	G1/2-A
MD-CDB-A1C2-T	5,0	11,0	0,8		75,0	
MD-CDB-A1C2-T	5,0	12,0	0,8		93,0	
MD-CDB-A1C2-T	6,0	12,0	0,8		75,0	
MD-CDB-A1C2-T	7,0	13,0	0,8		75,0	
MD-CDB-A1C2-T	7,2	12,0	0,8		75,0	
MD-CDB-A1C2-T	8,0	14,0	0,8		75,0	
MD-CDB-A1C2-T	8,0	15,0	0,8		75,0	
MD-CDB-A1C2-T	10,0	17,0	0,8		75,0	
MD-CDB-A1C2-T	11,0	16,0	0,8		75,0	
MD-CDB-A1C2-T	12,0	19,0	0,9		75,0	
MD-CDB-A1C2-T	12,0	19,0	0,9		93,0	
MD-CDB-A1C2-T	12,0	20,0	0,8		75,0	
MD-CDB-A1C2-T	12,7	19,0	0,8		75,0	
MD-CDB-A1C2-T	14,0	21,0	0,9		6,0	
MD-CDB-A1C2-T	14,0	21,0	0,9	93,0		
MD-CDB-A1C2-T	15,0	23,0	1,0	75,0		
MD-CDB-A1C2-T	16,0	23,0	0,8	75,0		
MD-CDB-A1C2-T	16,0	26,0	1,0	93,0		
MD-CDB-A1C2-T	16,0	26,0	1,0	75,0		
MD-CDB-A1C2-T	16,0	26,0	1,0	75,0		
MD-CDB-A1C2-T	16,0	24,0	0,8	75,0		

## MD-CDB-A1C2

CODE / 代码	ØD, mm	ØD <sub>1</sub> , mm	b	H, mm	L, mm	Ød, mm	
MD-CDB-A1C2-T	18,0	26,0	1,0	6,0	75,0	G1/2-A	
MD-CDB-A1C2-T	18,0	28,0	1,0		93,0		
MD-CDB-A1C2-T	20,0	28,0	0,8		75,0		
MD-CDB-A1C2-T	20,0	30,0	1,0		75,0		
MD-CDB-A1C2-T	20,0	30,0	1,0		93,0		
MD-CDB-A1C2-T	22,0	32,0	1,0		75,0		
MD-CDB-A1C2-T	24,0	34,0	0,8		75,0		
MD-CDB-A1C2-T	25,0	31,0	1,0		75,0		
MD-CDB-A1C2-T	25,0	35,0	1,0		93,0		
MD-CDB-A1C2-T	26,0	32,0	0,8		75,0		
MD-CDB-A1C2-T	26,0	34,0	1,0		75,0		
MD-CDB-A1C2-T	26,0	34,0	1,0		93,0		
MD-CDB-A1C2-T	26,0	36,0	1,0		75,0		
MD-CDB-A1C2-T	26,0	36,0	1,0		93,0		
MD-CDB-A1C2-T	27,0	35,0	1,0		75,0		
MD-CDB-A1C2-T	28,2	36,2	1,0		75,0		
MD-CDB-A1C2-T	35,0	41,0	1,0		75,0		
MD-CDB-A1C2-T	35,5	42,5	0,8		77,0		
MD-CDB-A1C2-T	38,0	44,0	1,0		75,0		
MD-CDB-A1C2-T	42,0	48,0	1,0		75,0		
MD-CDB-A1C2-T	45,2	52,2	1,0		75,0		
MD-CDB-A1C2-T	55,0	55,0	1,0		75,0		
MD-CDB-A1C2-C	6,0	13,0	0,8		75,0		Ø6,0
MD-CDB-A1C2-C	7,0	12,0			60,0		Ø7,0
MD-CDB-A1C2-C	8,0	15,0			75,0		Ø6,0
MD-CDB-A1C2-C	10,0	17,0			60,0		Ø6,0
MD-CDB-A1C2-C	10,0	17,0			75,0		Ø6,0
MD-CDB-A1C2-C	11,0	18,0			75,0		Ø6,0
MD-CDB-A1C2-C	12,0	19,0			75,0		Ø6,0
MD-CDB-A1C2-C	13,0	20,0			75,0		Ø6,0
MD-CDB-A1C2-C	14,0	21,0		75,0	Ø6,0		
MD-CDB-A1C2-C	26,0	32,0		60,0	Ø10,0		
MD-CDB-A1C2-U	10,0	16,0		116,0	Ø16,0		
MD-CDB-A1C2-U	16,0	22,0		116,0			

MD-CDB-A1C2 若没有上面表格的尺寸和连接头，可根据客户的要求定做

The special points MD-CDB-A1C2 of other sizes and connections are available upon customer's request

\* 以上任意 ØD 30mm 作为特殊定单

\* Any order above 30mm of ØD is considered as special order

定货代码: MD-CDB-A1C2-C

定货代码: MD-CDB-A1C2-T

定货代码: MD-CDB-A1C2-U

ØD/ØD<sub>1</sub> / - L - Ød

ØD/ØD<sub>1</sub> / - L

ØD/ØD<sub>1</sub> / - L

## 整体取芯 / MONOBLOCK CORE

### MD-CDB-MC2-T

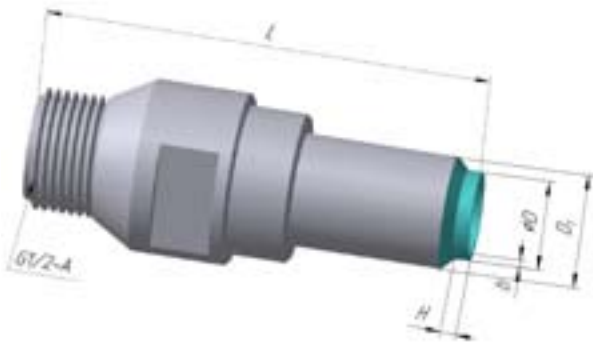

### MD-CDB-MC2-T\*

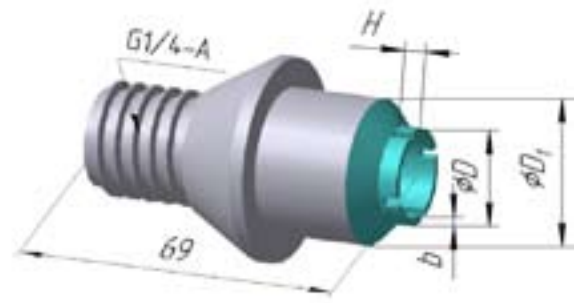

CODE/代码	ØD, mm	ØD <sub>1</sub> , mm	b	H, mm	L, mm	Ød, mm
MD-CDB-MC2-T	17,2	21,2	0,8	1,5	78,0	G1/2-A
MD-CDB-MC2-T *	10,0	15,0	0,8	2,0	34,5	G1/4-A
MD-CDB-MC2-T *	20,0	25,0	0,8	2,0	34,5	G1/4-A
MD-CDB-MC2-T *	26,0	31,0	0,8	2,0	34,5	G1/4-A

MD-CDB-MC2若没有上面表格的尺寸和连接头，可根据客户的要求定做

The special points MD-CDB-MC2 of other sizes and connections are available upon customer's request

\* 以上任意 ØD 30mm 作为特殊定单

\* Any order above 30mm of ØD is considered as special order

定货代码: MD-CDB-MC2-T

定货代码: MD-CDB-MC2-T\*

ØD/ØD<sub>1</sub> / - H - L

ØD/ØD<sub>1</sub> / - H - L

## 螺旋形 / SPIRAL

## MD-MC-S2-T

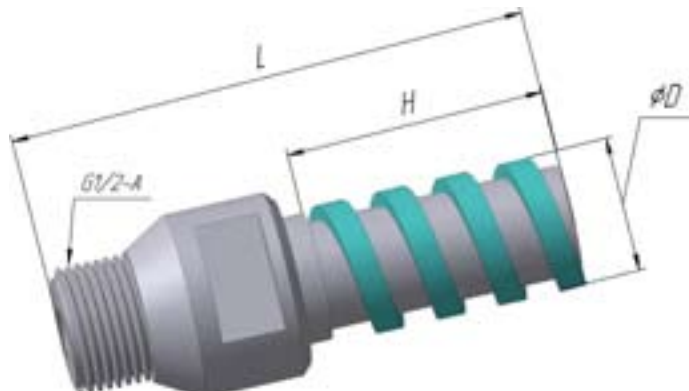

## MD-MC-S2-C

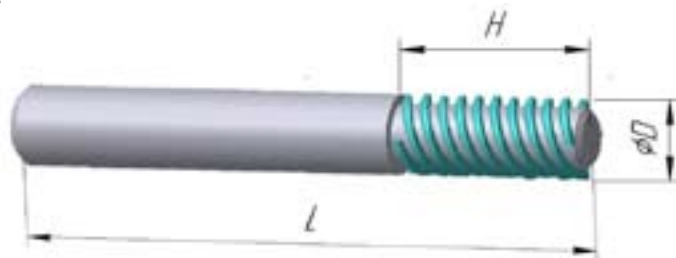

CODE/代码	ØD, mm	H, mm	L, mm		Ød, mm
MD-MC-S2-T	20,0	40,0	80,0	4螺旋螺杆微调	G1/2-A
MD-MC-S2-T	10,0	20,0	75,0	6螺旋螺杆微调	G1/2-A
MD-MC-S2-C	4,0	10,0	54,0	4螺旋螺杆微调	Ø6,0
MD-MC-S2-C	8,0	20,0	45,0	6螺旋螺杆微调	Ø6,0
MD-MC-S2-C	8,0	20,0	50,0	6螺旋螺杆微调	Ø12,0
MD-MC-S2-C	10,0	35,0	95,0	6螺旋螺杆微调	Ø6,0

MD-MC-S2 若没有上面表格的尺寸和连接头，可根据客户的要求定做

The special points MD-MC-S2 of other sizes and connections are available upon customer's request

\* 以上任意ØD 30mm作为特殊定单

\* Any order above 30mm of ØD is considered as special order

定货代码: MD-MC-S2-T

ØD x H \_\_\_\_\_ - L \_\_\_\_\_

定货代码: MD-MC-S2-C

ØD x H \_\_\_\_\_ - L \_\_\_\_\_ - Ød \_\_\_\_\_

值的 / STRAIGHT /

圆柱 / CYLINDER

MD-MC-S3-T

MD-MC-C3-T

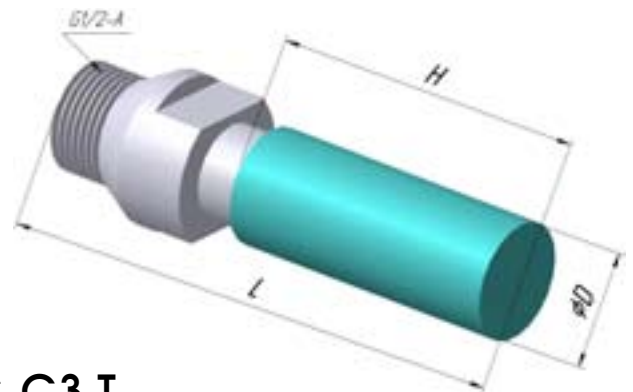
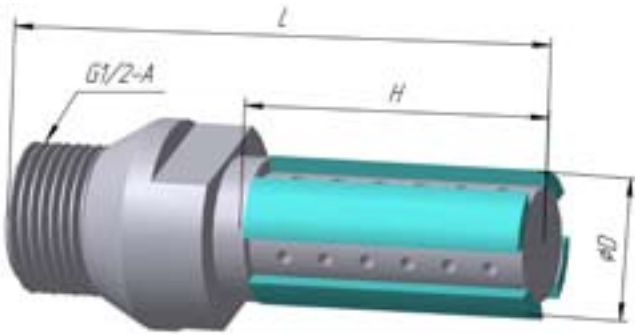

MD-MC-C3-T

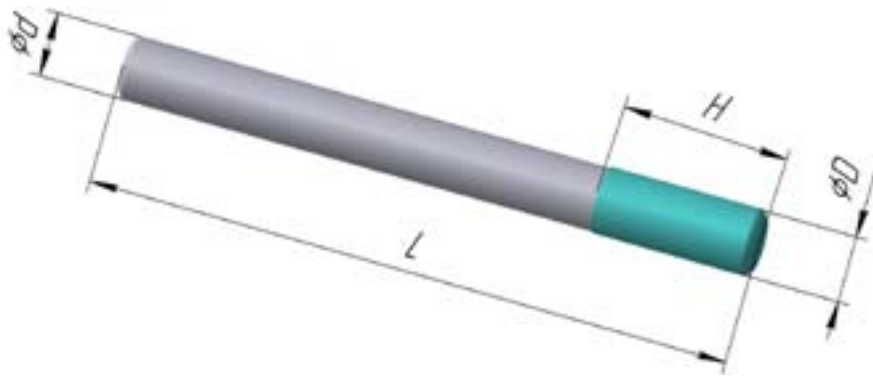

CODE/代码	ØD, mm	H, mm	L, mm	形状	Ød, mm
MD-MC-S3-T	20,0	40,0	75,0	圆柱形-4 槽	G1/2-A
MD-MC-S3-T	20,0	40,0	75,0	圆柱形-8 槽	G1/2-A
MD-MC-C3-T	22,0	55,0	95,0	圆柱形	G1/2-A
MD-MC-C3-C	6,0	8,0	45,0	圆柱形	Ø12,0

MD-MC-S3 和 MD-MC-C3 若没有上面表格的尺寸和连接头，可根据客户的要求定做

The special points MD-MC-S3 und MD-MC-C3 of other sizes and connections are available upon customer's request

\* 以上任意ØD 30mm作为特殊定单

\* Any order above 30mm of ØD is considered as special order

定货代码: MD-MC-S3-T

ØD x H \_\_\_\_\_ - L \_\_\_\_\_

定货代码: MD-MC-C3-T

ØD x H \_\_\_\_\_ - L \_\_\_\_\_

定货代码: MD-MC-C3-C

ØD x H \_\_\_\_\_ - L \_\_\_\_\_ - Ød \_\_\_\_\_

## 内圆 / INTERNAL ROUNDED

MD-PB-RI-T

MD-PB-RI-C

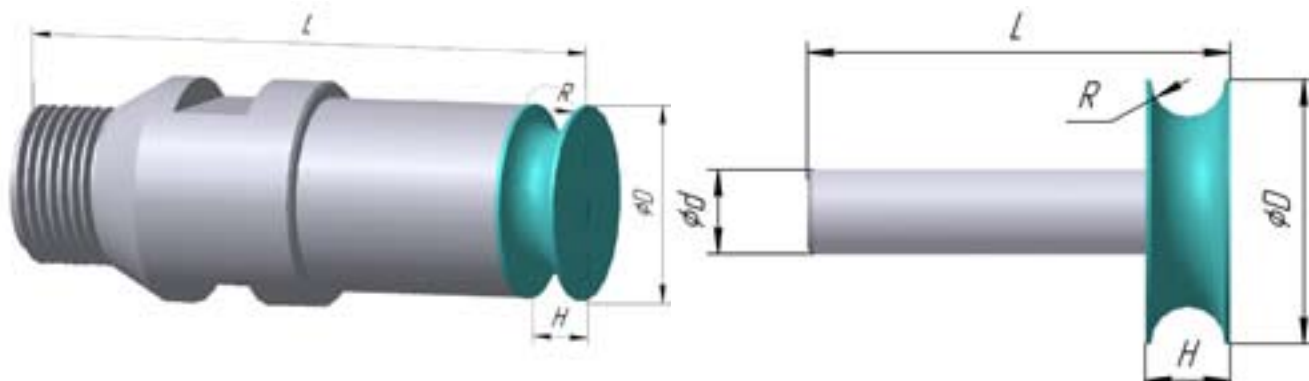

CODE/代码	ØD, mm	H, mm	R, mm	L, mm	Ød, mm
MD-PB-RI-T	21,0	17,6	10,9	110,0	G1/2-A
MD-PB-RI-T	25,0	8,0	3,3	75,0	
MD-PB-RI-T	25,0	11,4	5,0	75,0	
MD-PB-RI-T	50,0	8,0	3,3	75,0	
MD-PB-RI-T	50,0	11,4	5,0	75,0	
MD-PB-RI-C	20,0	10,0	5,67	40,0	Ø6,0
MD-PB-RI-C	21,0	14,0	8,75	44,0	
MD-PB-RI-C	25,0	8,0	3,3	40,0	
MD-PB-RI-C	25,0	11,4	5,0	40,0	

MD-PB-RI 若没有上面表格的尺寸和连接头，可根据客户的要求定做

The special points MD-PB-RI of other sizes and connections are available upon customer's request

\* 以上任意ØD 30mm作为特殊定单

\* Any order above 30mm of ØD is considered as special order

定货代码: MD-PB-RI-T

ØD x H\_\_ - R\_\_ - L\_\_

定货代码: MD-PB-RI-C

ØD x H\_\_ - R\_\_ - L\_\_ - Ød\_\_

## 梯形/ TRAPEZOIDAL

### MD-PB-T-T

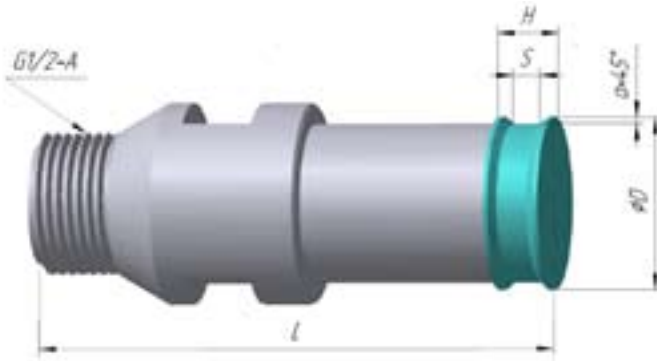

### MD-PB-T-C

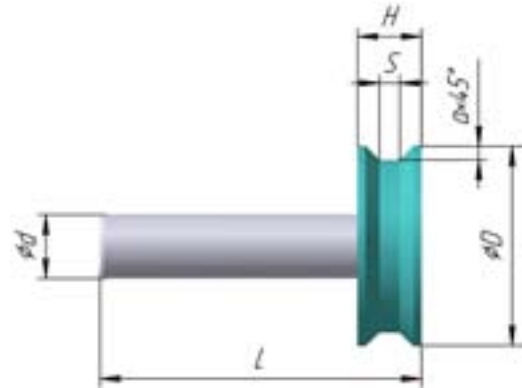

CODE/代码	ØD, mm	H, mm	S, mm	L, mm	α, mm	Ød, mm
MD-PB-T-T	14,0	26,0	20,0	85,0	2,0	G1/2-A
MD-PB-T-T	22,0	16,0	2,0	75,0	5,5	
MD-PB-T-T	24,0	13,6	3,6	80,0	2,0	
MD-PB-T-T	24,0	15,5	5,5	75,0	2,0	
MD-PB-T-T	24,0	17,0	7,0	75,0	2,0	
MD-PB-T-T	25,0	26,6	15,6	80,0	2,5	
MD-PB-T-T	25,0	8,0	2,5	75,0	1,75	
MD-PB-T-T	25,0	9,0	3,5	75,0	1,75	
MD-PB-T-T	25,0	10,0	4,5	75,0	1,75	
MD-PB-T-T	25,0	12,0	6,5	75,0	1,75	
MD-PB-T-T	25,0	14,0	8,5	75,0	1,75	
MD-PB-T-T	44,0	26,0	20,0	85,0	2,0	
MD-PB-T-C	15,0	8,0	2,5	44,0	1,75	
MD-PB-T-C	15,0	10,0	4,5	44,0	1,75	
MD-PB-T-C	25,0	8,0	2,5	40,0	1,75	Ø8,0

MD-PB-T 若没有上面表格的尺寸和连接头，可根据客户的要求定做

The special points MD-PB-T of other sizes and connections are available upon customer's request

\* 以上任意ØD 30mm作为特殊定单

\* Any order above 30mm of ØD is considered as special order

定货代码: MD-PB-T-T

ØD x H\_\_ - S\_\_ - L\_\_

定货代码: MD-PB-T-C

ØD x H\_\_ - S\_\_ - L\_\_ - Ød\_\_

## 外角 / EXTERNAL ANGULAR

## MD-W-A2E

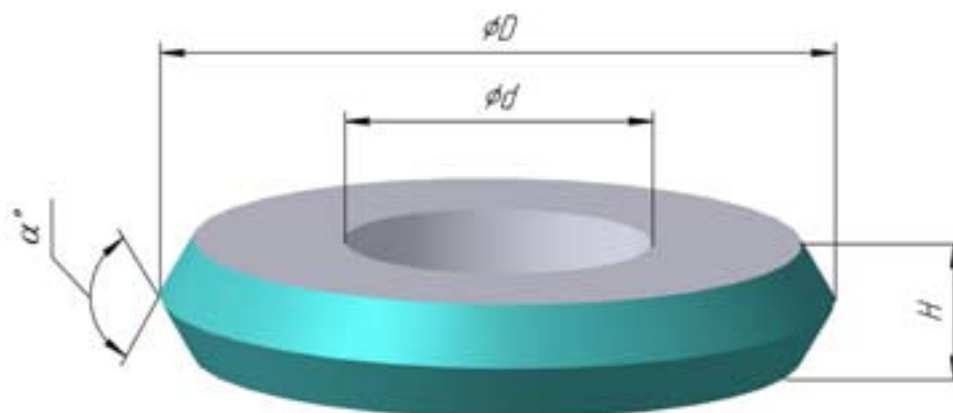

CODE/代码	ØD, mm	H, mm	α°	Ød, mm
MD-W-A2E	40,0	2,0	60	14,0
MD-W-A2E	50,0	3,0	30	20,0
MD-W-A2E	50,0	3,0	45	20,0
MD-W-A2E	50,0	3,0	60	20,0
MD-W-A2E	50,0	3,0	75	20,0
MD-W-A2E	50,0	3,0	90	20,0
MD-W-A2E	50,0	10,0	90	20,0
MD-W-A2E	65,0	10,0	90	20,0
MD-W-A2E	70,0	12,0	120	32,0

MD-W-A2E 若没有上面表格的尺寸和连接头，可根据客户的要求定做

The special points MD-W-A2E of other sizes and connections are available upon customer's request

\* 以上任意ØD 30mm作为特殊定单

\* Any order above 30mm of ØD is considered as special order

定货代码: MD-W-A2E

ØD x H \_\_\_ α° \_\_\_ - Ød \_\_\_



# 轮 / DISC

## MD-W-D

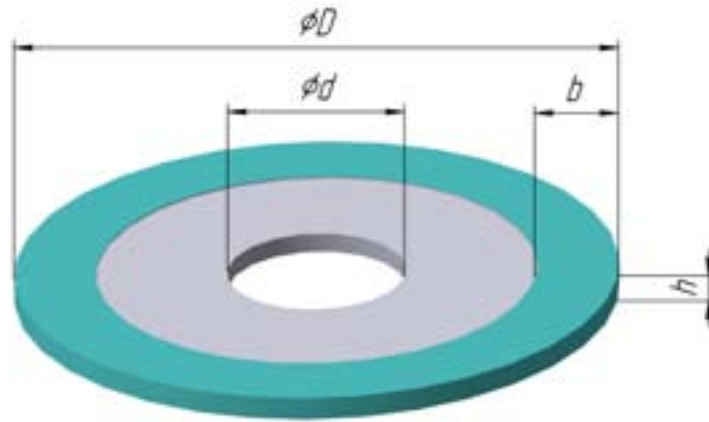

CODE/代码	$\phi D$ , mm	H, mm	b, mm	$\phi d$ , mm
MD-W-D	8,0	1,0	3,0	2,5
MD-W-D	12,0	1,0	3,0	4,5
MD-W-D	16,0	1,0	3,0	6,5
MD-W-D	25,0	0,5	10,0	7,5
MD-W-D	40,0	0,8	10,0	10,0
MD-W-D	40,0	1,0	10,0	15,0
MD-W-D	50,0	1,0	10,0	20,0
MD-W-D	70,0	1,0	15,0	13,0
MD-W-D	74,0	2,0	32,0	9,0
MD-W-D	80,0	1,0	15,0	8,0
MD-W-D	80,0	1,2	15,0	8,0

MD-W-D 若没有上面表格的尺寸和连接头，可根据客户的要求定做

The special points MD-W-D of other sizes and connections are available upon customer's request

\* 以上任意 $\phi D$  30mm作为特殊定单

\* Any order above 30mm of  $\phi D$  is considered as special order

定货代码: MD-W-D       $\phi D \times H$  \_\_\_ - b \_\_\_ -  $\phi d$  \_\_\_

## 外圆 / EXTERNAL ROUNDED

## MD-W-RE

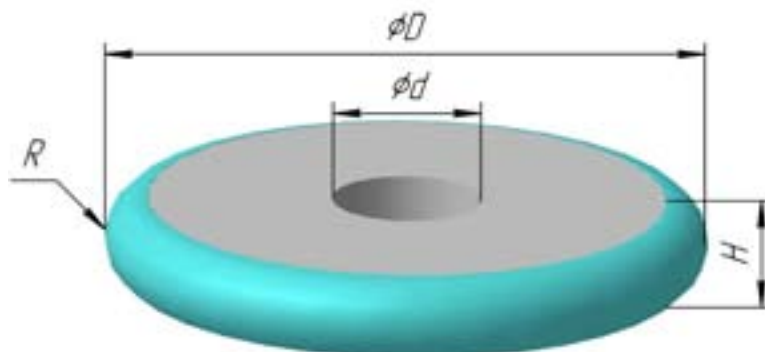

CODE/代码	ØD, mm	H, mm	R, mm	Ød, mm
MD-W-RE	30,0	3,0	1,5	12,0
MD-W-RE	50,0	3,0	1,5	20,0
MD-W-RE	50,0	4,0	2,0	20,0
MD-W-RE	50,0	5,0	2,5	20,0
MD-W-RE	50,0	6,0	3,0	20,0
MD-W-RE	50,0	7,0	3,5	20,0

MD-W-RE 若没有上面表格的尺寸和连接头，可根据客户的要求定做

The special points MD-W-RE of other sizes and connections are available upon customer's request

\* 以上任意ØD 30mm作为特殊定单

\* Any order above 30mm of ØD is considered as special order

定货代码: MD-W-RE      ØD x H \_\_\_ - R \_\_\_ - Ød \_\_\_

## 内圆 / INTERNAL ROUNDED

### MD-W-RI

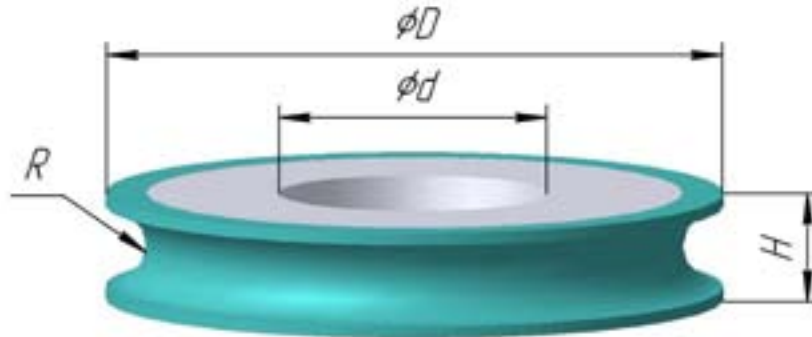

CODE/代码	ØD, mm	H, mm	R, mm	Ød, mm
MD-W-RI	40,0	14,0	5,0	22,0
MD-W-RI	50,0	8,6	3,3	22,0
MD-W-RI	50,0	12,0	5,0	22,0
MD-W-RI	70,0	8,0	3,3	32,0

MD-W-RI 若没有上面表格的尺寸和连接头，可根据客户的要求定做

The special points MD-W-RI of other sizes and connections are available upon customer's request

\* 以上任意ØD 30mm作为特殊定单

\* Any order above 30mm of ØD is considered as special order

定货代码: MD-W-RI      ØD x H\_\_\_ - R\_\_\_ - Ød\_\_\_

## 直的 / STRAIGHT

## MD-W-S3

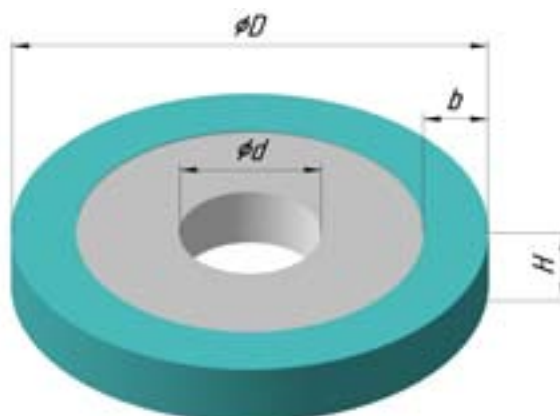

CODE/代码	$\varnothing D$ , mm	H, mm	b, mm	$\varnothing d$ , mm
MD-W-S3	13,0	10,0	2,0	4,0
MD-W-S3	15,0	5,0	2,0	5,0
MD-W-S3	16,0	5,0	2,0	6,0
MD-W-S3	16,0	16,0	2,0	6,0
MD-W-S3	20,0	10,0	1,5	7,0
MD-W-S3	20,0	5,0	2,0	10,0
MD-W-S3	20,0	20,0	2,0	6,0
MD-W-S3	20,0	25,0	1,5	6,0
MD-W-S3	25,0	5,0	2,0	6,0
MD-W-S3	25,0	15,0	2,0	10,0
MD-W-S3	30,0	30,0	3,0	16,0
MD-W-S3	30,0	30,0	2,0	10,0
MD-W-S3	30,0	5,0	2,0	20,0
MD-W-S3	32,0	4,0	3,5	10,0
MD-W-S3	35,0	3,5	2,0	6,0
MD-W-S3	35,0	4,0	2,0	10,0
MD-W-S3	40,0	5,0	3,0	16,0
MD-W-S3	40,0	5,0	2,0	20,0
MD-W-S3	41,7	10,0	2,0	14,0
MD-W-S3	50,0	50,0	4,0	16,0
MD-W-S3	60,0	6,0	2,0	32,0

MD-W-S3 若没有上面表格的尺寸和连接头，可根据客户的要求定做

The special points MD-W-S3 of other sizes and connections are available upon customer's request

\* 以上任意 $\varnothing D$  30mm作为特殊定单

\* Any order above 30mm of  $\varnothing D$  is considered as special order

定货代码: MD-W-S3       $\varnothing D$  x H \_\_\_ - b \_\_\_ -  $\varnothing d$  \_\_\_

## 梯形 / TRAPEZOIDAL

### MD-W-T

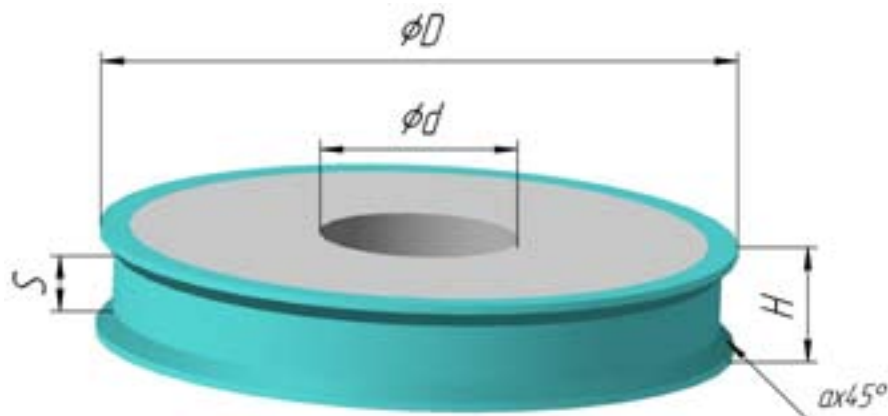

CODE/代码	ØD, mm	H, mm	S, mm	α, mm	Ød, mm
MD-W-T	25,0	15,5	6,5	2,0	11,8
MD-W-T	50,0	8,0	2,5	1,75	32,0
MD-W-T	50,0	9,0	3,5		32,0
MD-W-T	50,0	10,0	4,5		32,0
MD-W-T	50,0	12,0	6,5		32,0
MD-W-T	50,0	14,0	8,5		32,0
MD-W-T	60,0	8,0	2,5		32,0
MD-W-T	70,0	12,0	6,5		22,0
MD-W-T	70,0	16,0	10,5		22,0

MD-W-T 若没有上面表格的尺寸和连接头，可根据客户的要求定做

The special points MD-W-T of other sizes and connections are available upon customer's request

\* 以上任意ØD 30mm作为特殊定单

\* Any order above 30mm of ØD is considered as special order

定货代码: MD-W-T      ØD x H \_\_\_ - S \_\_\_ - Ød \_\_\_



广州红风进出口  
贸易有限公司

电话： 13929577241  
 QQ： 1954371500  
 E-mail： niccomail@163.com  
 www.chinaredwind.com